

CITY OF OAKLAND

Parks and Recreation Advisory Commission



AGENDA FOR REGULAR MEETING

Date: Wednesday, June 10, 2026

Time: 4:30 PM

Location: Lakeside Park Garden Center, 666 Bellevue Avenue

Remote access instructions:

The following options are available to join this meeting remotely via Zoom;

- To join online, please click on the following link: <https://us06web.zoom.us/j/88919233846>.
- To join by phone, please use one of the options below:
 - One-tap mobile.
 - +16699006833,,85665572470# US, +14086380968,,85665572470# US (San Jose)
 - Dial one of the numbers below for higher quality based on your current location.
 - +1 669 900 6833 US (San Jose), +1 408 638 0968 US (San Jose),
 - +1 669 444 9171 US, +1 253 215 8782 US (Tacoma),
 - +1 346 248 7799 US (Houston), +1 719 359 4580 US, +1 253 205 0468 US,
 - +1 309 205 3325 US, +1 312 626 6799 US (Chicago), +1 360 209 5623 US,
 - +1 386 347 5053 US, +1 507 473 4847 US, +1 564 217 2000 US,
 - +1 646 876 9923 US (New York), +1 646 931 3860 US, +1 689 278 1000 US,
 - +1 301 715 8592 US (Washington DC), +1 305 224 1968 US
 - International numbers are available at <https://us06web.zoom.us/j/88919233846>.
 - Webinar ID: 889 1923 3846.

How to submit Public Comment before and during the meeting:

1. To submit comments for review by the Commission before the meeting date, email comments to publiccomments2prac@oaklandca.gov.
2. To comment in person during the meeting, please complete a Speaker Card and provide to meeting coordinators before the Chair opens the floor to Public Comment on that Item. Each speaker will be called to the podium by name and permitted to comment for the allotted time.
3. To comment during the meeting online, click “Raise Your Hand” when prompted. When it is your turn to speak, please unmute yourself. You will be permitted to comment on the open Item for the allotted time and re-muted. See instructions on how to “Raise Your Hand” here: https://support.zoom.com/hc/en/article?id=zm_kb&sysparm_article=KB0068290.
4. To comment during the meeting by phone, please call one of the phone numbers listed above. You will be prompted to “Raise Your Hand” by dialing *9 to request to speak. When it is your turn, please unmute yourself by dialing *6. You will be permitted to comment on the open Item for the allotted time and re-muted.

If you have questions, email publiccomments2prac@oaklandca.gov or contact Oakland Parks, Recreation and Youth Development at 510-238-7275. Thank you.

AGENDA FOR REGULAR MEETING

Parks and Recreation Advisory Commission

Date: Wednesday, June 10, 2026

Time: 4:30 PM

Location: Lakeside Park Garden Center, 666 Bellevue Avenue



NOTE: Public Comment will be taken during this meeting as follows...

- If you have a comment to make about an Item on this agenda, you may do so after the Chair opens the floor to Public Comment on that Item.
- If you have a comment to make about a topic that is not on this agenda, you may do so under **Items 5 and 10**, Open Forum and Continuation of Open Forum.

Agenda Items

1. Call to Order
2. Roll Call / Determination of Quorum
 - Alper, Barach, Cervantes, Henderson, Kos-Read, Omolo, Thomas, Tran, Watkins, Whitmore
3. Modification of the Agenda
4. Disposition of Minutes
 - Draft minutes from regular meeting on **May 13, 2026**.
5. Open Forum
 - Comment on all items not on this agenda will be taken at this time.
6. Measure Q Update
 - Monthly OPW Informational Report on Measure Q and Performance Measure Updates.
 - No report this month.
7. New Business
 - 7A. Request for the Parks and Recreation Advisory Commission (PRAC) to approve the installation of the Tupac Shakur Peace Pole at East Shore Park in celebration of the Tupac Shakur Day 2026: A Day of Peace, Community & Culture Event on Tuesday, June 16, 2026, from 9:00am – 1:00pm.
 - 7B. Request for the Parks and Recreation Advisory Commission to approve a gift-in-place donation for forty-nine thousand nine hundred and seventy dollars (\$49,970) from the M10 Alliance Group for the repair of the emergency exit stairs at Defremery Park Recreation Center.

AGENDA FOR REGULAR MEETING

Parks and Recreation Advisory Commission

Date: Wednesday, June 10, 2026

Time: 4:30 PM

Location: Lakeside Park Garden Center, 666 Bellevue Avenue

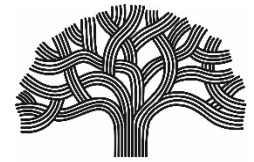

CITY OF OAKLAND

7C. Request for the Parks and Recreation Advisory Commission to approve Royal Grand Ducal Council of Alameda & Contra Costa Counties Inc. ticket sales at door, alcohol beverage sales, vendor sales of merchandise, tips and donations at the Corona on XXXIV – Clash of the Titans to be held at Lakeside Park Garden Center (Vista & Garden Rooms), Saturday, July 18, 2026 from 5:00pm – 9:30pm.

8. Planning and Conditional Use Permits (CUPs)

9. Update from the Director, Committees, and Announcements

10. Continuation of Open Forum

– All final comments on items not on this agenda will be taken at this time.

11. Adjournment

AGENDA FOR REGULAR MEETING

Parks and Recreation Advisory Commission

Date: Wednesday, June 10, 2026

Time: 4:30 PM

Location: Lakeside Park Garden Center, 666 Bellevue Avenue



Visit [PRAC's website](#) for Agendas, Meetings, Minutes, and more information.

Next Regular PRAC Meeting

Date: Wednesday, July 8, 2026

Time: 4:30 PM

Location: Lakeside Park Garden Center, 666 Bellevue Avenue

Accessibility Information:

This meeting location is wheelchair accessible.

To request disability-related accommodations or to request an ASL, Cantonese, Mandarin or Spanish interpreter, please email publiccomments2prac@oaklandca.gov or call Oakland Parks, Recreation and Youth Development at (510) 238-7275 or TDD/TTY (510) 238-3254 at least ten (10) days before the meeting. Please refrain from wearing scented products to this meeting as a courtesy to attendees with chemical sensitivities. Thank you.

Esta reunión es accesible para sillas de ruedas. Si desea solicitar adaptaciones relacionadas con discapacidades, o para pedir un intérprete de en español, Cantonés, Mandarín o de lenguaje de señas (ASL) por favor envíe un correo electrónico a publiccomments2prac@oaklandca.gov o llame al (510) 238-7275 o (510) 238-3254 por lo menos cinco (5) días hábiles antes de la reunión. Se le pide de favor que no use perfumes a esta reunión como cortesía para los que tienen sensibilidad a los productos químicos. Gracias.

會場有適合輪椅出入設施。需要殘障輔助設施, 手語, 西班牙語, 粵語或國語翻譯服務, 請在會議前五個工作天電郵 publiccomments2prac@oaklandca.gov 或致電 (510) 238-7275 或 (510) 238-3254 TDD/TTY。請避免塗搽香氛產品, 參加者可能對化學成分敏感。

CITY OF OAKLAND
Parks and Recreation Advisory Commission



MINUTES FOR REGULAR MEETING

Date: Wednesday, May 13, 2026

Time: 4:30 PM

Location: Lakeside Park Garden Center, 666 Bellevue Avenue

Agenda Items

1. Call to Order: **4:42 p.m.**

2. Roll Call / Determination of Quorum

Alper, Barach, Cervantes, Henderson, Kos-Read, Omolo, Thomas, Tran, Watkins, Whitmore

Present (8): Chair Barach, Vice Chair Omolo, Commissioners Cervantes, Henderson, Kos-Read, Thomas, Tran, Watkins.

Remote (1): Commissioner Whitmore.

Excused (1): Commissioner Alper.

Absent (0):

Action: Quorum confirmed.

3. Modification of the Agenda

– **None.**

4. Disposition of Minutes

– Draft minutes from regular meeting on **April 8, 2026.**

– Draft minutes from special meeting on **April 17, 2026.**

Motion: Chair Barach entertained a motion to approve the minutes.

Moved by: Commissioner Tran

Seconded by: Commissioner Kos-Read

Vote: Yes (9) Barach, Omolo, Cervantes, Henderson, Kos-Read
Thomas, Tran, Watkins, and Whitmore.

No (0)

Action: Motion Passed.

5. Open Forum

– Comment on all items not on the agenda are taken at this time.

In-Person: 0

Remote: 0

Email: 2

6. Measure Q Update

- Monthly OPW Informational Report on Measure Q and Performance Measure Updates.
 - No report this month.

7. New Business

7A. Pro Tem election for July PRAC Meeting.

Motion: Chair Barach entertained a motion to nominate Com. Tran.

Moved by: Commissioner Watkins

Seconded by: Commissioner Kos-Read

Vote: Yes (9) Barach, Omolo, Cervantes, Henderson, Kos-Read, Thomas, Tran, Watkins, and Whitmore.
No (0)

Action: Motion Passed.

Public Comment

In-Person: 0

Remote: 0

Email: 0

7B. Informational report on the proposed Sobrante Field renovation and public-private partnership with Oakland Genesis Soccer Club.

Public Comment

In-Person: 1

Remote: 1

Email: 0

Motion: Chair Barach entertained a motion to accept and file the report.

Moved by: Commissioner Watkins

Seconded by: Vice Chair Omolo

Vote: Yes (9) Barach, Omolo, Cervantes, Henderson, Kos-Read, Thomas, Tran, Watkins, and Whitmore.
No (0)

Action: Motion Passed.

8. Planning and Conditional Use Permits (CUPs)

None.

9. Update from the Director, Committees, and Announcements

Director's Update:

- Myka Hammock is now the permanent Director of OPRYD.
- Mosswood Grand Opening last weekend was well attended. Stop by and ask for a tour!
- The 73rd Annual Mother of the Year Awards recognized Mama C.

Announcements:

- Com. Tran: Summer Nights is beginning through October at Lincoln Recreation Center, 2nd Thursdays, 5 – 8p.
- Asst. CIP Coordinator, Quincy Williams: Approval for Contractor for Lincoln Recreation Center renovation will be on June City Council agenda. Groundbreaking eta August 2026. The East Oakland Art Center, formerly DACA, is complete. Opening this summer. Tyrone Carney Park ribbon cutting TBD August 2026. FRC emergency funds for repair of septic and drinking water systems secured.
- Com. Kos-Read: Sunday, Salsa by the Lake will be at the bandstand from 2 – 5p. Every Friday there are raves with vendors at Lake Merritt. Cease and desist letters have been served.
- Chair Barach: There was a rave party Saturday at Joaquin Miller Park creating fire risk. OPD was informed and intervened. The last rave was held in October 2025. OPRYD and OPW staff met with Friends of JMP discussing areas to block off with logs and added signage. Requesting contacts to follow up.

10. Continuation of Open Forum

- Final comments on items not on the agenda are taken at this time.

In-Person: 0

Remote: 0

11. Adjournment: **5:40 p.m.**

Motion: Chair Barach entertained a motion to adjourn the meeting.

Moved by: Commissioner Kos-Read

Seconded by: Commissioner Tran

Vote: Yes (9) Barach, Omolo, Cervantes, Henderson, Kos-Read, Thomas, Tran, Watkins, and Whitmore.

No (0)

Action: Motion Passed.

Next Regular PRAC Meeting

Date: Wednesday, June 10, 2026

Time: 4:30 PM

Location: Lakeside Park Garden Center, 666 Bellevue Avenue

Visit [PRAC's website](#) for Agendas, Meetings, Minutes, and more information.

Respectfully submitted,



Jasmine S. Bellow

Executive Assistant to the Director

PRAC Recording Secretary

DRAFT



CITY OF OAKLAND
Oakland Parks, Recreation & Youth Development

TO: Marc Barach, Chair, Parks & Recreation Advisory Commission
FROM: Zermaine Thomas, Special Events Coordinator, Central Reservations Unit
DATE: June 1, 2026
SUBJECT: REQUEST FOR PARKS AND RECREATION ADVISORY COMMISSION (PRAC) TO APPROVE THE INSTALLATION OF THE TUPAC SHAKUR PEACE POLE AT EAST SHORE PARK IN CELEBRATION OF THE TUPAC SHAKUR DAY 2026: A DAY OF PEACE, COMMUNITY & CULTURE EVENT ON TUESDAY, JUNE 16, 2026, FROM 9:00AM-1:00PM

SUMMARY

Oakland Parks, Recreation & Youth Development (OPRYD) received a request from Charles Johnson, Co-Producer of SoulBeat TV Network and Tupac Shakur Day 2026, seeking approval to install the Tupac Shakur Peace Pole at East Shore Park. SoulBeat is co-producing the event in partnership with the Tupac Amaru Shakur Foundation (TASF), a 501(c)(3) organization dedicated to identifying and eradicating the effects of trauma through programs focused on mental health, prison reform, domestic violence, human trafficking, social justice, and the creative arts.

Pending approval, the Peace Pole will be installed immediately to commemorate the Tupac Shakur Day of Peace, Community & Culture. The event will take place at East Shore Park on Tuesday, June 16, 2026, from 9:00 am to 1:00 pm.

BACKGROUND / LEGISLATIVE HISTORY

For over 30 years, Oakland's own SoulBeat TV Network remains one of the Bay Area's most enduring independent media and cultural institutions. SoulBeat, long serving as the original lens for Oakland's unique cultural identity, SoulBeat's legacy includes hosting one of the first West Coast hip-hop television shows, producing BET's Hyphy Week, and serving as Media Consultant and Community Liaison to former Mayor Ron Dellums.

PROJECT / PROGRAM DESCRIPTION

Tupac Shakur Day 2026 is a citywide celebration of peace, community, and culture, honoring what would be Tupac Shakur's 55th birthday in the city that shaped him. Produced in partnership with the Tupac Amaru Shakur Foundation (TASF), the event has the full support of the City of Oakland from the Mayor's Office to City Council and features the active participation of Sekyiwa Shakur, TASF President and sister of the late artist.

The day consists of three core components:

- **The Peace Pole Ceremony:** Held at East Shore Park near Tupac Shakur Way, this unity ceremony will open the day and anchor a permanent civic monument to Tupac's legacy in the neighborhood that bears his name.
- **The Health & Wellness Village:** Located in the Henry J. Kaiser Center for the Arts parking lot, this village will offer free health screenings (including blood pressure, diabetes, and A1C checks), mental health resources, and healthcare services provided in partnership with the Bay Area Black Nurses Association, Kaiser Permanente, and Roots Community Health.
- **The Legacy Benefit Concert:** Hosted by Sway Calloway, this concert will raise proceeds to directly benefit the Tupac Amaru Shakur Foundation.

FISCAL IMPACT

There is no fiscal impact on Oakland Parks, Recreation & Youth Development. The Peace Pole is fully funded by Soul Beat TV Network and Tupac Amaru Shakur Foundation (TASF) and will be installed by Oakland Public Work (OPW).

PUBLIC OUTREACH / INTEREST

Tupac Shakur Day 2026 will be promoted through a comprehensive media and marketing campaign spanning local civic press including KTVU, KRON, as well as national hip-hop and cultural media including Sway in the Morning. The event will also be supported by a social media countdown campaign, influencer activation, and live broadcast with global streaming potential. Key spokespeople include Sekyiwa Shakur and Bay Area recording artists. The event has the official support of the City of Oakland.

COORDINATION

OPRYD staff worked closely with the event promoter, Councilmember Fife's Office, and Oakland Public Works (OPW) to ensure the placement and installation of the Tupac Shakur Peace Pole.

RECOMMENDATION

Staff recommend that the Parks and Recreation Advisory Commission approve the request for the installation of the Tupac Shakur Peace Pole at East Shore Park in celebration of the Tupac Shakur Day 2026: A Day of Peace, Community & Culture on Tuesday, June 16, 2026, from 9:00am-1:00pm

Respectfully submitted,

Zermaine Thomas

Prepared by:

Zermaine Thomas

Special Events Coordinator

Sarah Herbelin

Sarah Herbelin (Jun 2, 2026 09:09:04 PDT)

Reviewed by:
Sarah Herbelin
Assistant Director, OPRYD

Myka Hammock

Myka Hammock (Jun 2, 2026 12:47:06 PDT)

Approved by:
Myka Hammock
Director, OPRYD

Attachments: Exhibit A – SoulBeat TV Network Proposal Letter
Exhibit B – Peace Pole Installation Site Map



SOULBEAT TV NETWORK

May 11, 2026

Dear Parks and Recreation Advisory Commission,

On behalf of SoulBeat TV Network, an Oakland-based cultural institution with over 30 years of service to the Bay Area community, please accept this Proposal Letter as part of our application for the use of East Shore Park on June 16, 2026, from 9am -1pm for the purpose of Tupac Shakur Day 2026: A Day of Peace, Community & Culture.

Brief History of Organization

SoulBeat TV Network was founded in Oakland over 30 years ago and remains one of the Bay Area's most enduring independent media and cultural institutions. SoulBeat has served as the original lens documenting Oakland's cultural identity — hosting one of the first hip-hop television programs on the West Coast, producing BET's Hyphy Week, and serving as Media Consultant and Community Liaison to Mayor Ron Dellums.

SoulBeat is co-producing Tupac Shakur Day 2026 in partnership with the Tupac Amaru Shakur Foundation (TASF), a 501(c)(3) private non-profit foundation whose mission is to identify and eradicate the effects of trauma on our community through programs focused on mental health and wellness, prison reform, domestic violence and human trafficking, social justice, and the creative arts as a healing tool.

Overview of Event

Tupac Shakur Day 2026 is a citywide day of peace, community, and culture honoring what would be Tupac Shakur's 55th birthday in the city that shaped him. The event is produced in partnership with the Tupac Amaru Shakur Foundation, with the full support of the City of Oakland from the Mayor's office to City Hall, and with the active participation of Sekyiwa Shakur, President of TASF and Tupac's sister. The day consists of three components.

The first is a Peace Pole Ceremony at East Shore Park near Tupac Shakur Way, a unity ceremony intended to open the day and anchor a permanent civic monument to Tupac's legacy in the neighborhood that bears his name. The second is a Health & Wellness Village in the Henry J. Kaiser Memorial Park parking lot, offering free health screenings to Oakland residents and event attendees — including blood pressure, diabetes, and A1C screenings, mental health providers, and services in partnership with Bay Area Black Nurses Association, Kaiser Permanente and Roots Community Health. The third component is a Legacy Benefit Concert hosted by Sway Callaway, with proceeds benefiting the Tupac Amaru Shakur Foundation.

No On-Site Fund Collection

SoulBeat TV Network and the Tupac Amaru Shakur Foundation will not be collecting any funds on-site at East Shore Park. Tupac Shakur Day 2026 is a free, open-to-the-public community event. All health screenings and wellness services in the Health & Wellness Village will be provided at no cost to attendees. Concert ticketing and fundraising activities associated with the Legacy Benefit Concert will be handled separately through established ticketing platforms and are not part of this parks use application.

Public Outreach and Interest

Tupac Shakur Day 2026 will be promoted through a comprehensive media and marketing campaign spanning local civic press — including KTVU, KRON, — as well as national hip-hop and cultural media including Sway in the Morning. The event will also be supported by a social media countdown campaign, influencer activation, and live broadcast with global streaming potential. Key spokespeople include Sekyiwa Shakur and Bay Area recording artists. The event has the official support of the City of Oakland.

Thank you, Commissioners, and the OPRYD staff for your support in ensuring our event is successful. Tupac Shakur Day 2026 represents a once-in-a-generation opportunity for Oakland to celebrate one of its most beloved cultural figures while delivering real, measurable health and community impact to the residents who need it most. We look forward to working with you.

Sincerely,

Charles Johnson Co-Producer, Tupac Shakur Day 2026 SoulBeat TV Network info@soulbeatnetwork.com
| (510) 776-4644 www.tupacday.com

Eastshore Park



Tupac Shakur Peace Pole Installation. The Peace Pole will be aligned with the Tupac Shakur Way Street Sign.



Imagery ©2026 Vexcel Imaging US, Inc., Map data ©2026 Google 20 ft

Tupac Shakur Peace Pole Installation: The Peace Pole will be aligned with the Tupac Shakur Way Street Sign, Grand Avenue veering towards MacArthur Blvd. Installation of Peace Pole is indicated by an X in the grassy area.



CITY OF OAKLAND
Oakland Parks, Recreation & Youth Development

TO: Marc Barach, Chair, Parks and Recreation Advisory Commission
FROM: Quincy Williams, Assistant Capital Improvement Project Coordinator, OPRYD
DATE: June 1, 2026
SUBJECT: REQUEST FOR THE PARKS AND RECREATION ADVISORY COMMISSION TO APPROVE A GIFT-IN-PLACE DONATION FOR FORTY-NINE THOUSAND NINE HUNDRED AND SEVENTY DOLLARS (\$49,970) FROM THE M10 ALLIANCE GROUP FOR THE REPAIR OF THE EMERGENCY EXIT STAIRS AT DEFREMERY PARK RECREATION CENTER

SUMMARY

DeFremery Mansion in West Oakland is one of the neighborhood's oldest surviving structures. Built in the 1870s as the home of a mixed-race couple, James de Fremery and Virginie Therese Herckenrath de Fremery. The property was acquired by the City of Oakland in 1909 and became one of the first public parks in the region.

Through much of the twentieth century, DeFremery Park and its surrounding facilities served as a vital center of life for West Oakland's Black community - hosting celebrations, civic gatherings, and the everyday activity that holds a neighborhood together. The mansion was also a gathering place for the Black Panthers and their massive food drive back in the day. In other words, the building has substantial historic importance, especially for the Black community in Oakland.

The mansion has not been adequately maintained for decades. Like many of Oakland's historic structures, it has been caught in a cycle of deferred investment - structurally significant, historically irreplaceable, and slowly deteriorating. The volunteer work in August 2026 is the first chapter in a longer story: a future in which the mansion is fully restored as a center for celebrating Black culture and community innovation in Oakland.

For two weeks in late August 2026, a team of around fifteen young people — five carpentry students from Mercantec vocational college in Denmark and around ten students from McClymonds High School in West Oakland - will carry out professionally prepared, supervised repair work that will include the following:

- On two stairways to the Social Hall at the end of the building
- On the operability of a set of windows sealed shut by accumulated paint (as time permits)

The scope is focused on repair rather than alteration: addressing deteriorating woodwork. All work will be planned and supervised by qualified master carpenters. Nothing about the building has changed. We intend to document the students' work in a few videos.

Each group of students will be well prepared for the work to be done; they will have a day together to get to know each other before the work starts, and supervisors will be around them at all times. The work will be organized so that each McClymonds High School student does not miss important schoolwork, which is why we will engage twice as many McClymonds students as Mercantec students.

BACKGROUND / LEGISLATIVE HISTORY

This project is structured to operate fully within California and federal law, with all parties appropriately protected.

- All volunteer labor is organized by M10 Alliance, fiscally sponsored by InterCulture Foundation (501(c)(3)), satisfying the volunteer exemption under California Labor Code §1720.4.
- The project scope is limited to repairing existing elements. No structural modifications are made to the building.
- All Danish participants — students and supervising teachers - are fully covered for travel, accommodation, potential visa costs, and insurance by Mercantec and the Danish government international education funding. Zero project funds are required for these costs.
- All McClymonds High School and Laney Community College will provide a certificate of insurance as required
- All material and tools are expected to be donated via McClymonds High School’s traditional partners.
- Any building permits needed will be filed with Oakland's Planning and Building Department before commencement of work.

PROJECT / PROGRAM DESCRIPTION

The Partners

Mercantec — Viborg, Denmark

Mercantec is a leading Danish vocational college with a strong tradition of international project-based learning. Its carpentry program is joining the college’s international program and is actively seeking meaningful real-world experiences for its students beyond Denmark's borders. Mercantec is responsible for recruiting, preparing, and accompanying the five Danish student volunteers, and for covering all costs of their travel, accommodation, visas, and insurance — funded through the Danish government. No project funds are required for the Danish participants.

McClymonds High School — West Oakland

McClymonds High School is one of the oldest and most storied schools in Oakland, deeply woven into the history of West Oakland's Black community. Generations of athletes, artists, and civic leaders have walked its halls. For McClymonds students, working on DeFremery Mansion is not an abstract community service project — it is working on their own neighborhood's history. Around 10 students will volunteer alongside their Danish peers, fully insured and supervised by qualified master carpenters. McClymonds High School holds its yearly alum gathering in DeFremery Park.

Laney Community College — Oakland

Laney Community College, home to one of the Bay Area's strongest construction trades programs, has expressed interest in participating in this project. We are currently formalizing their role, which will include providing supervision as a master carpenter alongside the Mercantec team. Laney's involvement connects this project to its broader mission of trades education and community development in Oakland and creates a potential pathway for McClymonds students into Laney's programs.

DeFremery Park, Greg McClain

DeFremery Park and the Mansion itself.

M10 Alliance, under InterCulture Foundation

M10 Alliance is the formal coordinator of this pilot and is taking initial steps towards financially supporting the restoration of the DeFremery Mansion and addressing potential needs in the park, benefiting the community. M10 Alliance is a project under InterCulture Foundation, a registered 501(c)(3) organization. InterCulture Foundation, established in 2008, operates in Oakland.

Project Coordination

Marianne Crary, M10 Alliance, representing Mercantec (program coordinator)
Gregg McClain, DeFremery Park & Recreation Center
Brian McGhee, McClymonds High School

The faculty members from Mercantec, Laney College, and McClymonds High School will prepare and supervise the actual work product.

What the Students Gain

Both groups of students leave this project with something that classroom instruction alone cannot provide.

For the Danish Students from Mercantec

- Hands-on application of carpentry skills in a genuinely important, historic context, new to them
- International project experience - increasingly valued in the European trades sector
- Immersion in Oakland's community, culture, and history
- A professional portfolio piece: documented restoration work on a historic civic structure
- Cross-cultural friendships and professional relationships that last beyond the project

For the McClymonds Students

- Skilled trades inspiration and learning alongside carpenter students and Master Carpenters from Mercantec and Laney College
- A direct, tangible contribution to their own neighborhood's history and built heritage
- Exposure to international peers and vocational education pathways
- A clear connection to trades careers and Laney Community College enrollment opportunities
- The experience of being trusted with something that genuinely matters
- Students will not operate any power tools

FISCAL IMPACT

There isn't a negative fiscal impact for the City of Oakland. The two-week volunteer project incurs no labor or material costs. All involved in the work are volunteering, and materials/tools are donated/lent.

PUBLIC OUTREACH / INTEREST

This project was proposed by Brian McGhee (McClymonds High School), Gregg McClain (DeFremery Park), and Marianne Crary (M10 Alliance). This pilot is the opening chapter of an intended larger initiative to restore DeFremery Mansion as a permanent center for the celebration of Black culture, history, and community innovation in Oakland - a gathering place, a celebration venue, and a home for organizations doing meaningful work in the community. We will start discussing this vision in the fall of 2026.

COORDINATION

In addition to M10 Alliance coordinating with the Danish government and McClymonds High School, OPRYD has communicated with Oakland Public Works (OPW) Facilities Service Division (FSD) to obtain approval for this project at DeFremery. OPW-FSD supports repairing the steps.

RECOMMENDATION

Staff recommends that the Park and Recreation Advisory Commission support a gift-in-place donation of forty-nine thousand nine hundred and seventy dollars (\$49,970) from the M10 Alliance group for the repair of the emergency exit stairs at DeFremery Park Recreation Center.

Respectfully submitted,

Quincy Williams (Jun 2, 2026 09:57:38 PDT)

Prepared by:
Quincy Williams
Assistant Capital Improvement Project Coordinator, OPRYD

Myka Hammock (Jun 2, 2026 12:46:08 PDT)

Approved by:
Myka Hammock
Director, OPRYD

Identification of Support Documents:

- Attachments: Exhibit A – Property Map
- Exhibit B – Current Steps and Future Design
- Exhibit C – Project Budget
- Exhibit D – MOU between McClymonds High School and Mercantec
- Exhibit E – Additional Support Documentation

Exhibit A – Property Map

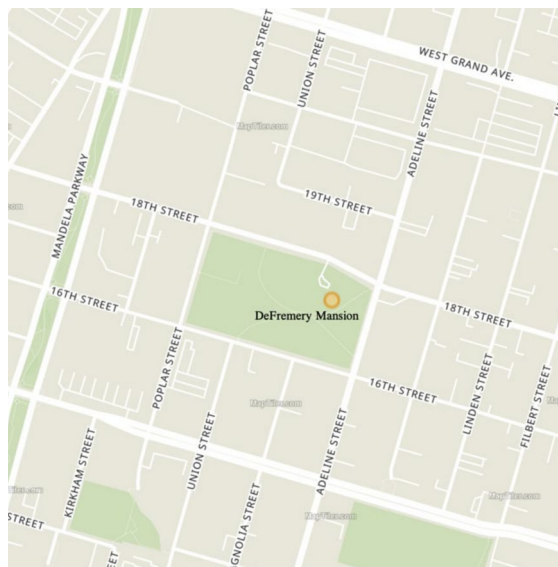
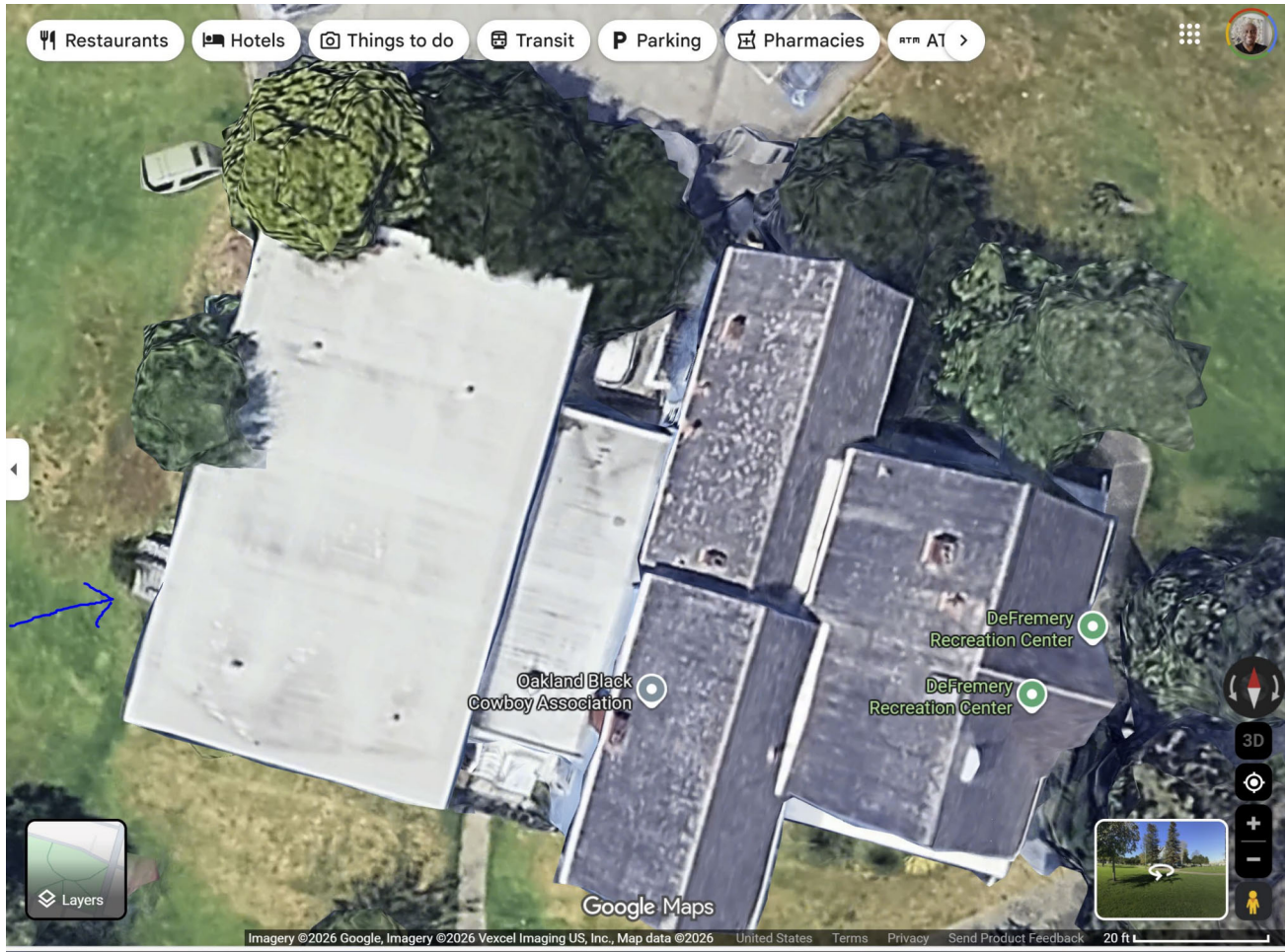
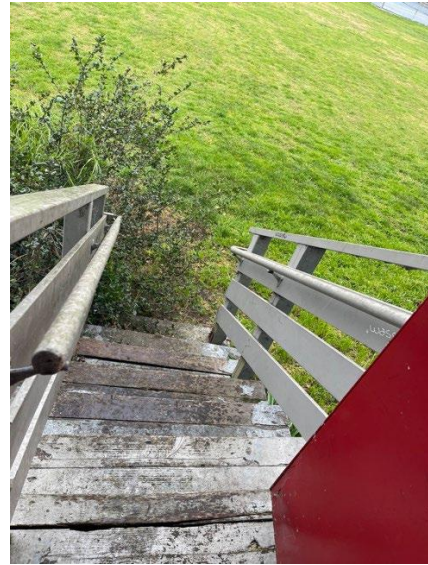
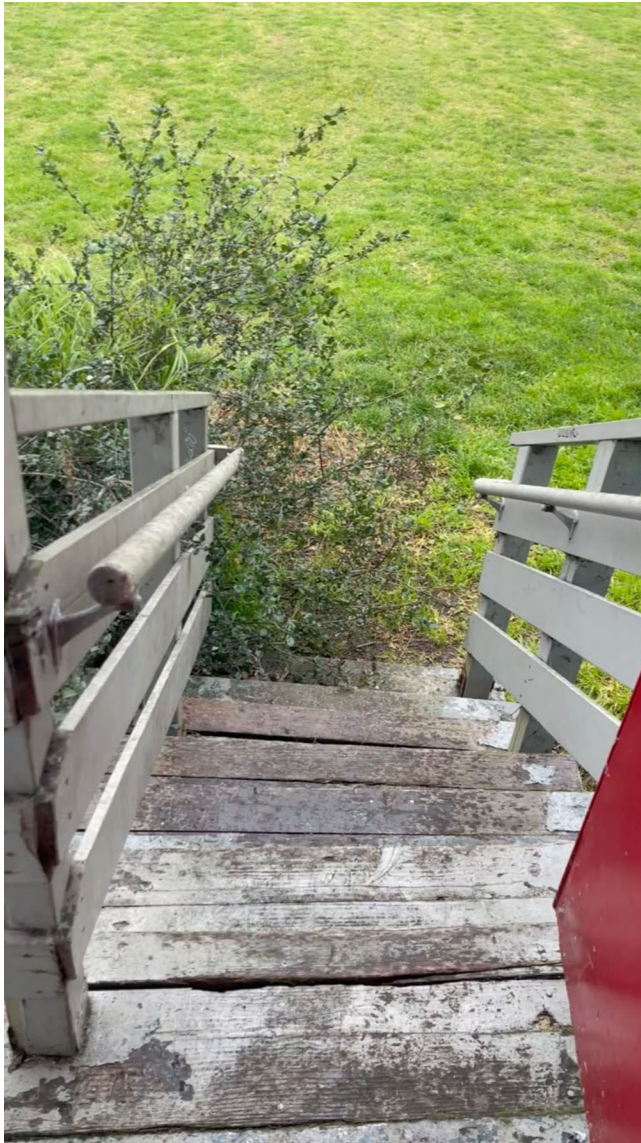

Exhibit B – Current Steps and Future Design



DEFREMERY HOUSE: STAIR REPAIR PROJECT

APPLICABLE CODES

2025 CALIFORNIA BUILDING CODE WITH CITY OF OAKLAND AMENDMENTS
 2025 CALIFORNIA ELECTRICAL CODE
 2025 CALIFORNIA FIRE CODE
 ALL OTHER APPLICABLE CITY, COUNTY AND STATE LAWS AND ORDINANCES

PROJECT DIRECTORY

ARCHITECT:
 ANNA DE ANGUERA
 494 37TH STREET
 OAKLAND, CA 94609

PHONE: 510.499.6427
 EMAIL: ANNA@STUDIOPEAR.US

PROJECT SPONSOR:
 M10 ALLIANCE

CONTACT: MARIANNE CRARY
 PHONE: 650.621.0880
 EMAIL: MMC@M10SOCIETY.COM

PROJECT DATA

SITE INFORMATION

ADDRESS: 1651 ADELINE ST, OAKLAND, CA 94607
 APN: 005 038900100

ZONING: O-S (CP), S-20
 LOT AREA: 9.44 ACRES

BUILDING:

YEAR BUILT: 1864
 EXISTING CONSTRUCTION TYPE: VB
 FIRE SPRINKLERS: YES
 EXISTING STORIES: 2

SCOPE OF WORK:
 REPLACE EXISTING WOOD STAIR FROM SOCIAL HALL IN-KIND WITH A NEW WOOD STAIR.

VICINITY MAP

N.T.S.

DRAWING INDEX

| SHEET NUMBER | SHEET NAME | PERMIT SUBMITTAL 05.07.2026 |
|--------------|--------------------------|-----------------------------|
| A0.01 | COVER SHEET | X |
| A1.01 | EXISTING PLAN | X |
| A2.01 | STAIR PLANS & ELEVATIONS | X |

DEFREMERY: STAIR REPAIR
 1651 ADELINE ST.
 OAKLAND, CA 94607

COVER SHEET

A0.01

© 2025 STUDIO PEAR, INC.

OAKLAND, CA
STUDIOPEAR.US

ISSUE DATE: 05/29/26

Description

No. Date

DEFREMERY: STAIR REPAIR
 1651 ADELINE ST.
 OAKLAND, CA 94607

EXISTING SITE PLAN

A1.00

1 EXISTING SITE PLAN

SCALE: 3/8" = 1'-0"

DEFREMERY: STAIR REPAIR
 1651 ADELINE ST.
 OAKLAND, CA 94607

EXISTING SITE PLAN

A1.00

© 2025 STUDIO PEAR, INC.

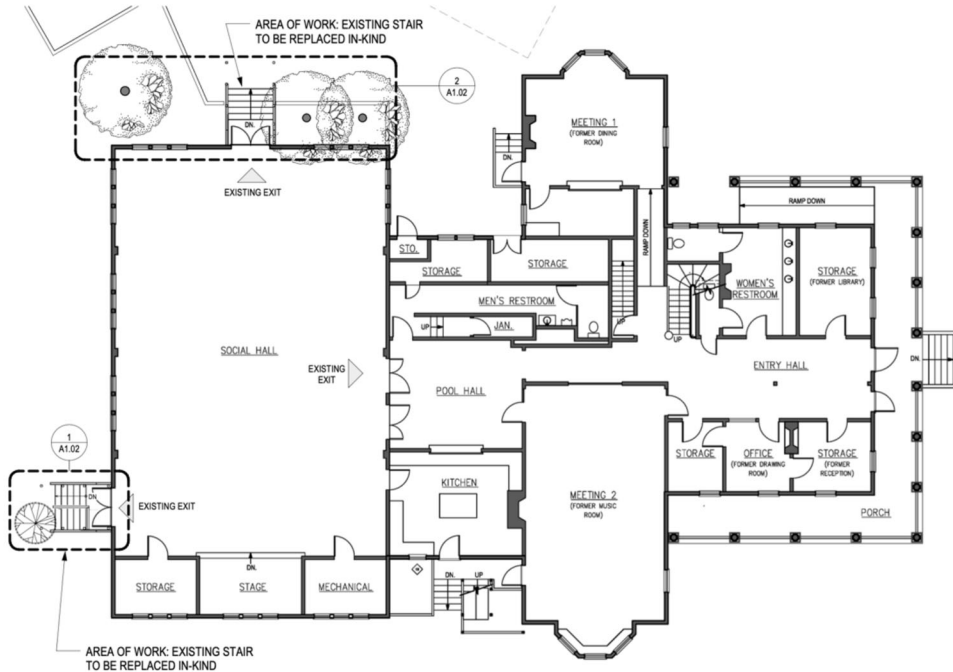

1 EXISTING FLOOR PLAN

SCALE: 1/32" = 1'-0"



| | |
|---|----------------------|
| STUDIO PEAR OAKLAND, CA STUDIOPEAR.COM | |
| Description | ISSUE DATE: 05/29/20 |
| No. Date | |
| DEFREMERY: STAIR REPAIR 1857 ADELINE ST. OAKLAND, CA 94607 | |
| EXISTING PLAN | |
| A1.01 | |

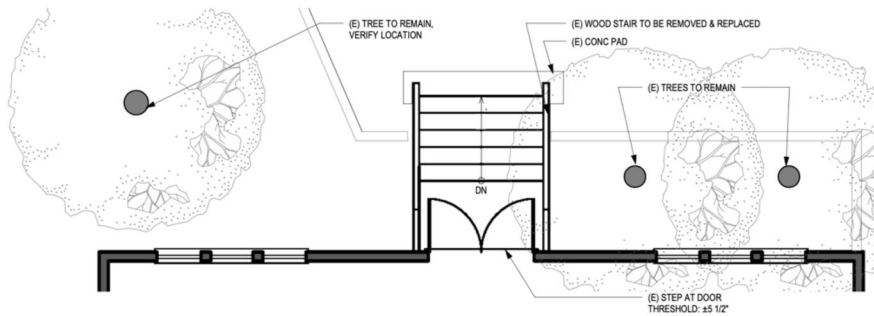

2 EXISTING NORTH STAIR PLAN

SCALE: 1/4" = 1'-0"

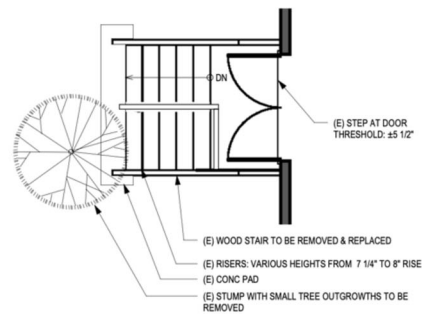

1 EXISTING WEST STAIR PLAN

SCALE: 1/4" = 1'-0"

| | |
|---|----------------------|
| STUDIO PEAR OAKLAND, CA STUDIOPEAR.COM | |
| Description | ISSUE DATE: 05/29/20 |
| No. Date | |
| DEFREMERY: STAIR REPAIR 1857 ADELINE ST. OAKLAND, CA 94607 | |
| EXISTING & DEMOLITION STAIR PLANS | |
| A1.02 | |

© 2020 STUDIO PEAR, INC.

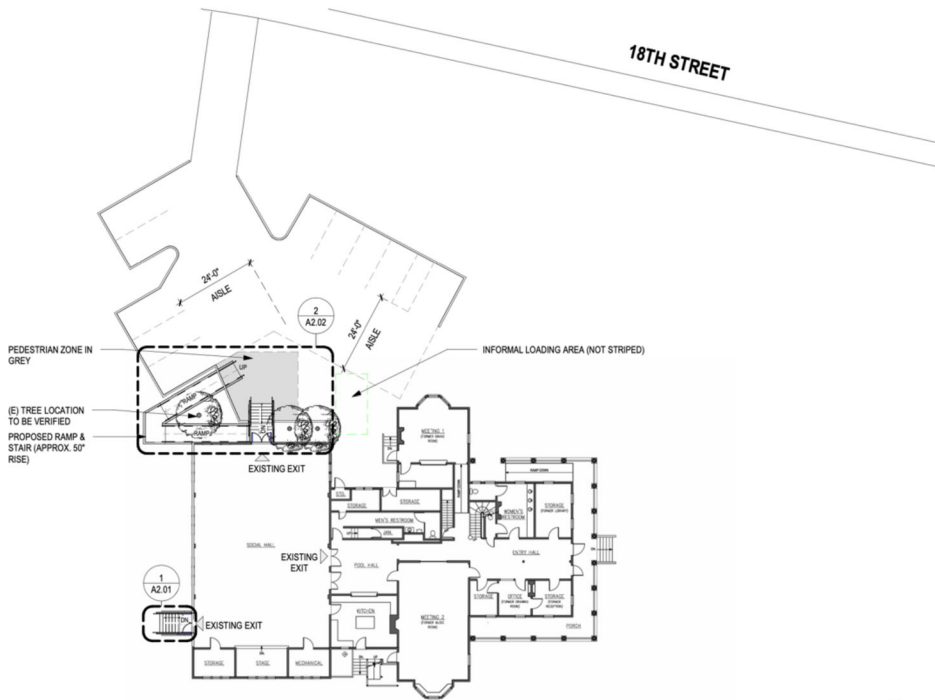

1 PROPOSED SITE PLAN

SCALE: 3/8" = 1'-0"



| | |
|------------------------------------|----------|
| | |
| ISSUE DATE: | 05/29/23 |
| No.: | Date: |
| Description: | |
| DEFREMERY: STAIR REPAIR | |
| 1851 ADELINE ST. OAKLAND, CA 94607 | |
| PROPOSED SITE PLAN | |
| A2.00 | |
| © 2023 STUDIO PEAR, INC. | |

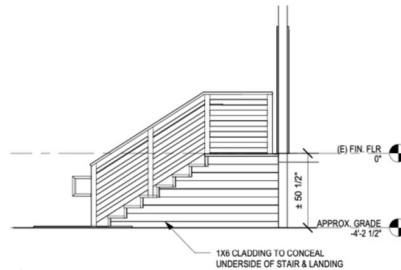

2 PROPOSED WEST STAIR ELEVATION

SCALE: 1/4" = 1'-0"

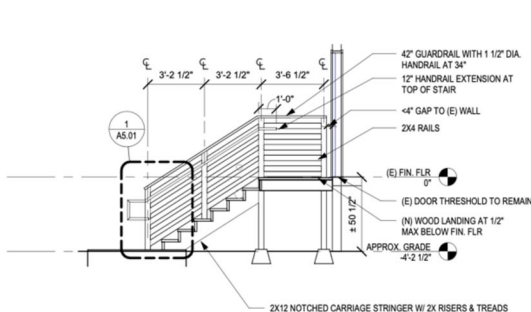

3 PROPOSED WEST STAIR SECTION

SCALE: 1/4" = 1'-0"

NOTE: ALL WOOD TO BE EXTERIOR GRADE (P.T. OR REDWOOD) FINISH: RAILINGS PAINTED WHITE & STAIR TREADS & RISERS GREY OR PER CITY'S DIRECTION

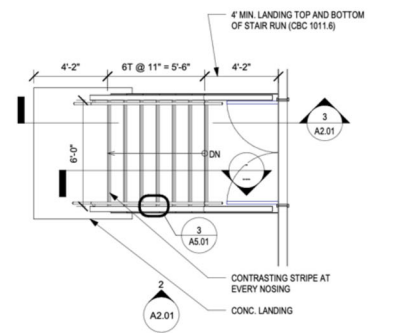

1 PROPOSED WEST STAIR PLAN

SCALE: 1/4" = 1'-0"

NOTE: PROVIDE ILLUMINATION VIA STEPLIGHTS EQUIVALENT TO 1 FOOTCANDLE

| | |
|------------------------------------|----------|
| | |
| ISSUE DATE: | 05/29/23 |
| No.: | Date: |
| Description: | |
| DEFREMERY: STAIR REPAIR | |
| 1851 ADELINE ST. OAKLAND, CA 94607 | |
| WEST STAIR PLANS & ELEVATIONS | |
| A2.01 | |
| © 2023 STUDIO PEAR, INC. | |

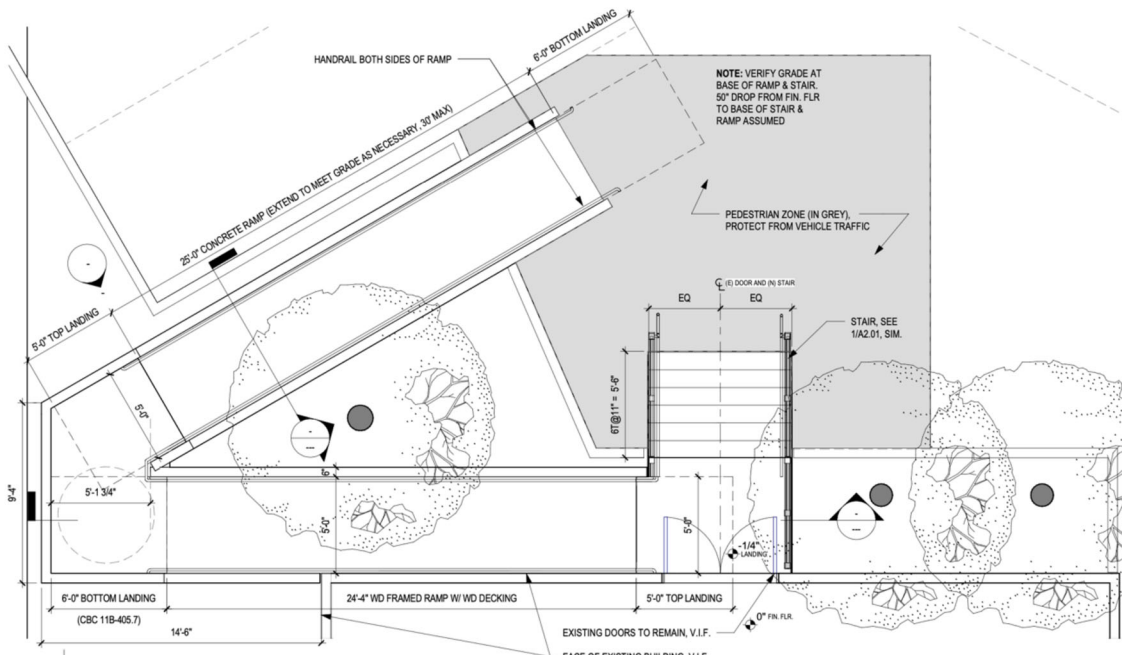

2 PROPOSED PLAN - NORTH STAIR & RAMP

SCALE: 1/4" = 1'-0"

STUDIO PEAR
OAKLAND, CA
STUDIOPEAR.US

ISSUE DATE: 05/29/26

Description

No. Date

DEFREMERY: STAIR REPAIR
1651 ADELINE ST.
OAKLAND, CA 94607

NORTH STAIR & RAMP PLAN

A2.02

© 2026 STUDIO PEAR, INC.

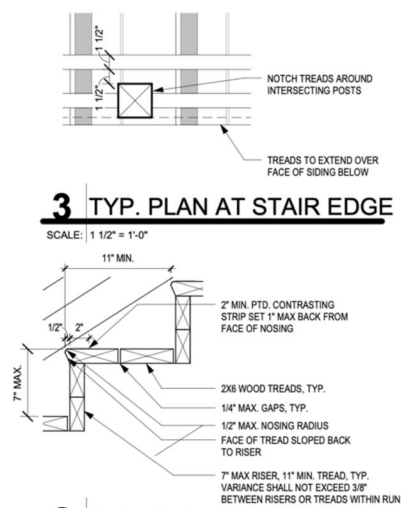

3 TYP. PLAN AT STAIR EDGE

SCALE: 1 1/2" = 1'-0"

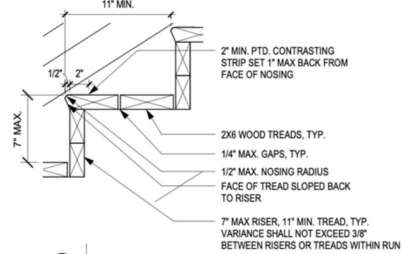

2 TYP. TREAD & RISER

SCALE: 1 1/2" = 1'-0"

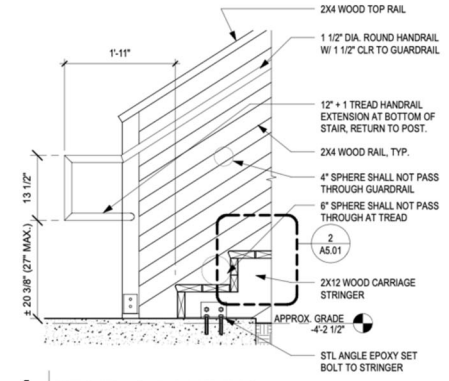

1 STAIR @ LANDING

SCALE: 3/4" = 1'-0"

STUDIO PEAR
OAKLAND, CA
STUDIOPEAR.US

ISSUE DATE: 05/29/26

Description

No. Date

DEFREMERY: STAIR REPAIR
1651 ADELINE ST.
OAKLAND, CA 94607

STAIR DETAILS

A5.01

© 2026 STUDIO PEAR, INC.

Exhibit C– Project Budget

| McClymonds on a Mission – estimated value of donated time and cost | Execution August 23- September 4, 2026 |
|---|---|
| Volunteering time, Danish carpenter apprentices (5) - 11 days | \$6,160 |
| Volunteering time McClymonds students (10) - 11 days | \$6,480 |
| Volunteering time Danish faculty/teachers (2) - 11 days | \$3,840 |
| Volunteering time McClymonds faculty/teachers (2) - 11 days | \$3,840 |
| Danish team travel expenses, flights/hotel | \$26,000 |
| Misc. extra expert time needed, just in case | \$3,500 |
| Volunteering time, material/tool advisor | \$150 |
| Material donated and borrowed tools | \$0 |
| Total | \$49,970 |

Exhibit D – MOU between McClymonds High School and Mercantec

MEMORANDUM OF UNDERSTANDING

Between

Mercantec, Denmark

and

McClymonds High School / Oakland Unified School District

"McClymonds on a Mission"

This Memorandum of Understanding ("MOU") is entered into as of April 1, 2026 ("Effective Date"), by and between:

Mercantec, a Danish Business and Technical Vocational College in the Danish vocational education system under the Ministry of Education ("Mercantec"); and

McClymonds High School, operated by Oakland Unified School District ("OUSD"), an independent public school district ("McClymonds").

Mercantec and McClymonds are referred to individually as a "Party" and collectively as the "Parties."

1. PURPOSE AND BACKGROUND

The Parties enter this MOU to formalize their collaboration in a project named "McClymonds on a Mission" - a community initiative that engages students in hands-on, professionally supervised repair work at DeFremery Mansion (located in DeFremery Park, Oakland, CA) and in a privately owned home in West Oakland.

The collaboration advances the following shared goals:

- Provide McClymonds students with authentic, career-connected learning experiences in carpentry, construction trades, and community stewardship.
- Strengthen cross-cultural educational exchange by partnering Oakland students with students and instructors from Mercantec.
- Support the long-term restoration of DeFremery Mansion as a potential Black cultural & community innovation center (DeFremery).
- Improve the life quality of an 80+ year old owner of a private home in West Oakland (Hattie's House)
- Deepen student civic engagement and sense of agency in their own community.

It is the intent of the Parties that this collaboration will continue after this pilot project with the two improvement projects.

2. SCOPE OF COLLABORATION

2.1 Student Participation

McClymonds agrees to facilitate the participation of ~10 interested students in supervised project activities. Student Participants are volunteers. Participation is optional, and no student is required to participate as a condition of enrollment, course completion, or grading.

Mercantec agrees to facilitate the participation of 5 carpenter students and their teacher (a Master Carpenter) in supervised project activities. Mercantec students are volunteers. Participation is

optional, and no student is required to participate as a condition of enrollment, course completion, or grading.

Anticipated activities include:

- Simple, carpentry and light construction tasks at DeFremery, possibly including window operability restoration, and deferred repair of the back stairs of the building.
- Simple, carpentry improvements of Hattie's House, e.g., safe access for the garden.
- Cross-cultural exchange sessions with Mercantec students and instructors from Denmark.
- Safety orientation and tool-use instruction provided by qualified instructors from Mercantec and Laney Community College.

2.2 Age and Parental Consent

Student Participants under the age of 18 must provide written parental or guardian consent prior to participation coordinated by the McClymonds. Signed consent forms must be present at Brian McGhee's office before any Student Participant joins a project activity. Mercantec students are minimum 18 years old and require no parental or guardian consent to participate.

2.3 Supervision

All Student Participants will be supervised at all times during project activities by qualified adults. Mercantec is responsible for on-site supervision during project activities. McClymonds may assign a staff liaison to coordinate logistics and communication but is not expected to provide on-site supervision of work activities unless otherwise agreed in writing. Laney Community College is expected to participate in supervision.

3. ROLES AND RESPONSIBILITIES

3.1 Mercantec's representative in the Bay Area, Marianne Cray

- Serves as lead coordinator for all project activities in collaboration with Mr. Brian McGhee and Mr. Jay Moffett, both representing McClymonds.
- Secure all required permits, licenses, and approvals from the City of Oakland, Oakland Parks, Recreation & Youth Development (OPRYD), and any other relevant authorities before commencing work – in collaboration with Mr. Gregg McClain, DeFremery Park and Quincy Williams, Assistant Capital Improvement Project Coordinator, Oakland Parks, Recreation, and Youth Development (OPRYD).
- Ensure that all project activities comply with applicable law under advice from Quincy Williams, Assistant Capital Improvement Project Coordinator, Oakland Parks, Recreation, and Youth Development (OPRYD).
- Ensure that all Mercantec participants are covered by required general liability insurance and volunteer accident insurance. Certificates of insurance will be provided to the Assistant Capital Improvement Project Coordinator Quincy Williams, Oakland Parks, Recreation, and Youth Development.
- Coordinate qualified instructors and/or licensed tradespeople to oversee hands-on construction activities.
- Ensure that general safety orientation is provided before work starts.
- Communicate project schedules, changes, and safety updates to the McClymonds liaison in a timely manner.
- Ensure Mercantec's signature on the final MOU.

3.2 McClymonds High School / OUSD

- Designate a staff liaison as primary point of contact for project coordination. McClymonds Liaison is Mr. Brian McGhee.
- Ensure that all McClymonds participants in the project are covered by required general liability insurance and volunteer accident insurance. Certificates of insurance will be provided to the Assistant Capital Improvement Project Coordinator Quincy Williams, Oakland Parks, Recreation, and Youth Development.
- Secure that all tools, materials, and personal protective equipment required for project activities is available and responsible for that this is ready at the two locations prior to start of the work.
- Maintain records of McClymond Student Participant attendance.
- Secure signed consent forms as needed, including consent forms for all students/parents to sign accepting participation in potential video and photo documentation of the project (For McClymonds students under 18, parent signatures are needed).
- Coordinate the distribution and collection of parental/guardian consent forms.
- Communicate project opportunities to students in a manner consistent with OUSD policies and procedures.
- Notify the Mercantec's representative promptly of any McClymonds student health, safety, or accommodation needs that may affect participation.
- Cooperate with Mercantec to support student participation in alignment with the McClymonds' academic calendar and applicable OUSD policies.
- Maintain a first aid kit on-site during all project activities.
- McClymonds will instruct Mercantec teacher about rules and regulations in California.
- Ensure McClymonds' signature on the final MOU.

4. STUDENT HEALTH, SAFETY, AND WELFARE

The safety and welfare of both Danish and School Participants is of paramount importance. The Parties agree that:

- No Student Participant will be required to perform any task that poses unreasonable risk to their health or safety. Students have agency to decline tasks, they don't think they are up for.
- All project activities involving students will be conducted in compliance with California Occupational Safety and Health Administration (Cal/OSHA) regulations and all applicable safety standards.
- Student Participants will be provided with appropriate personal protective equipment for the work activities.
- The instructors will have a safety plan in place for each project activity and will conduct a safety orientation for all Participants prior to the commencement of work.
- McClymonds will maintain a first aid kit on-site during all project activities.
- In the event of an injury or emergency involving a Student Participant, Mr. McGhee or Mr. Moffett will immediately contact emergency services, the student's parent or guardian (as applicable).
- Student Participants may withdraw from any activity at any time without penalty.

Nothing in this MOU is intended to waive either Party's governmental immunities or other legal defenses. Each Party is responsible for its own acts, omissions, and negligence.

5. NO EMPLOYMENT RELATIONSHIP; VOLUNTEER STATUS

All Danish and all McClymonds Participants are volunteers and are not employees, agents, or contractors. This MOU does not create an employment relationship between any of the participating students and any Party. Student Participants will not receive wages, salaries, or other compensation for their participation in project activities. Nothing in this MOU shall be construed to create a formal joint venture, partnership, agency relationship, or employment relationship between the Parties.

6. NON-DISCRIMINATION

The Parties agree that project activities will be conducted in a manner consistent with all applicable federal and state non-discrimination laws and OUSD's non-discrimination policies. No student will be excluded from participation on the basis of race, color, national origin, sex, gender identity, sexual orientation, disability, religion, age, or any other characteristic protected by applicable law.

7. CONFIDENTIALITY AND STUDENT PRIVACY

The Parties will comply with all applicable federal and state laws governing student privacy, including the Family Educational Rights and Privacy Act (FERPA) and the California Student Privacy Act. Mercantec will not collect, use, or disclose personally identifiable student information except as necessary to administer this MOU and with the prior written consent of OUSD/McClymonds as required by applicable law. McClymonds will instruct Mercantec about this and other rules and regulations in California.

9. MEDIA, PHOTOGRAPHY, AND PUBLICITY

Mercantec and McClymonds may document project activities through photography, video, and other media for purposes of reporting, fundraising, and public communications. Any use of images or video that identifies by name Student Participants will require separate written consent from the student's parent or guardian (for students under 18) or the student (for students 18 and over), consistent with OUSD policies. The Parties will coordinate on any press releases or public announcements that reference both organizations.

10. TERM AND TERMINATION

This MOU is effective as of the Effective Date and will remain in effect until end of year 2026, unless earlier terminated. The initial term covers the pilot project phase from end of August 2026 to early September 2026.

The MOU can be extended as needed when both parties are interested in that.

Either Party may terminate this MOU at any time upon thirty (30) days' written notice to the other Party. Either Party may terminate this MOU immediately upon written notice if:

- The other Party materially breaches this MOU and fails to cure the breach within ten (10) days of written notice; or
- Continuation of the project would pose an unreasonable risk to student safety or welfare.

Termination of this MOU will not affect any obligations that have already arisen, including Mercantec's and McClymonds' obligation to ensure the safety of Student Participants in ongoing activities.

11. AMENDMENT

This MOU may be amended only by a written instrument signed by authorized representatives of both Parties.

12. ENTIRE AGREEMENT

This MOU constitutes the entire agreement between the Parties with respect to the subject matter hereof and supersedes all prior discussions, understandings, and agreements relating thereto. This MOU does not obligate either Party to expend funds or commit resources beyond those expressly described herein.

13. GOVERNING LAW

This MOU is governed by the laws of the State of California, without regard to its conflict of law principles. Any dispute arising under this MOU will be subject to good-faith negotiation between the Parties before either Party pursues other remedies.

14. AUTHORIZED REPRESENTATIVES AND NOTICES

Each Party represents that the individual signing below has the authority to enter into this MOU on behalf of their respective organization. Notices under this MOU should be directed to the individuals identified in the signature block below, or as updated by written notice.

SIGNATURES

IN WITNESS WHEREOF, the Parties have executed this Memorandum of Understanding as of the date last signed below.



Susanne Joel
Leader of International Department
Mercantec, Denmark
Date:



Name
Title
McClymonds High School / OUSD
Date:

 **Mercantec**
H.C. Andersens Vej 9 • 8800 Viborg
Tlf. +45 89 50 33 00
mercantec@mercantec.dk
www.mercantec.dk

Exhibit E – Additional Support Documentation



Alejandria Tomas
Dean of Career & Technical Education/Athletics
Laney College
900 Fallon Street, Oakland, CA 94607
(510) 464-3218 | laney.edu | atomas@peralta.edu

March 31, 2026

RE: Letter of Support for “McClymonds on a Mission”

To Whom It May Concern,

Laney College is pleased to support the “McClymonds on a Mission” pilot project, a collaboration between McClymonds High School and Mercantec College educators and students. As a leader in career technical education, Laney’s Carpentry and Construction Trades programs are committed to hands-on learning, workforce pathways, and community impact.

This project aligns strongly with our mission by introducing high school students to construction careers through meaningful, real-world experience while improving housing conditions in West Oakland. The combination of skill-building, mentorship, and cross-cultural exchange creates a powerful model for student engagement and community benefit.

Laney College intends to support this effort in the following ways (August/September 2026):

1. In collaboration with the Danish Master Carpenter and faculty from Mercantec College, provide college-level guidance in the development of a comprehensive student work plan, including advising on materials selection, tool use, and appropriate safety and security protocols.
2. Explore pathways for McClymonds students into Laney’s construction programs.
3. Support early college credit opportunities, as resources allow.
4. Facilitate interaction between McClymonds and Laney carpentry students.
5. Participate in documentation and future project planning.

We are excited about the potential of this initiative and its long-term benefits for students and the Oakland community.

Sinceley,

Alejandria Tomas
Laney College
Dean of Career and Technical Education

Mercantec is one of 76 Business and Tech Vocational Colleges in Denmark, all of which are 100% financed by the Danish Government, as is most education in Denmark.

- Mercantec is a self-governed educational institutional focused on business & technology
 - Business high school & VET college
 - Technology high school & VET colleges
 - Continuing technical & business education for adult learners (re- & upskilling)
 - 50 business & technical programs housed in 5 colleges
 - Building, Center for Advanced Technology, Business College, Culinary Arts College, and Business & Tech High School
 - Certified ED Center of Excellence in Learning
 - Appr. 15,000 students (2,500 FTE students)
 - 450 employees
 - Multi-site institution, headquartered in Viborg, Denmark
 - Colleges with a total of 253 class/training rooms
 - Equity of \$23M in 2024, total turnover of approximately \$42M yearly
 - International partners in UK, EU, Africa, Middle East, Far East and the US (systems export and exchange programs)
-

Vocational education (VET) in Denmark

The Danish VET model stands out

- **Dual model**, combining work-based apprenticeships with school-based learning, ensuring strong ties between education and the labor market (industry and unions), which play a significant role in shaping curricula to meet and **adjust to industry fast changing needs** at national and local level
 - Danish VET allows for **upward mobility** through pathways to higher education, such as academy profession degrees and professional bachelor programs
 - Denmark excels in adult vocational training. Combined VET completion-age in average is 28, in the rest of the EU it is 21. This is due to **significant accommodation to adult learners**, often sent by their employers to re- or upskill leading to a **faster transition in industry than seen in other countries**
 - 117 VET schools/colleges of which **76 business/tech colleges** (1 per 80,000 population)
 - Some of the VET schools/colleges are certified **European Centers of Excellence** in specific fields of education
 - Denmark participates in national and European **Championships** in a variety of trade excellence
 - Danish VET student are offered international opportunities – education and internships, incl. in the US
-

PRAC Staff Report DeFremery and OUSD





6.1.26

Final Audit Report

2026-06-02

| | |
|-----------------|--|
| Created: | 2026-06-02 (Pacific Daylight Time) |
| By: | Ayanna Jennings (ASJennings@oaklandca.gov) |
| Status: | Signed |
| Transaction ID: | CBJCHBCAABAAZqNEoxZJFNvwGMO3FG9jKU9EKalpHH2H |

"PRAC Staff Report DeFremery and OUSD 6.1.26" History

-  Document created by Ayanna Jennings (ASJennings@oaklandca.gov)
2026-06-02 - 9:54:45 AM PDT - IP address: 209.232.103.89
-  Document emailed to Quincy Williams (QWilliams@oaklandca.gov) for signature
2026-06-02 - 9:55:41 AM PDT
-  Email viewed by Quincy Williams (QWilliams@oaklandca.gov)
2026-06-02 - 9:57:07 AM PDT - IP address: 209.232.103.91
-  Document e-signed by Quincy Williams (QWilliams@oaklandca.gov)
Signature Date: 2026-06-02 - 9:57:38 AM PDT - Time Source: server- IP address: 209.232.103.91 - Signature Appearance Selected: DRAW
-  Document emailed to Myka Hammock (MHammock@oaklandca.gov) for signature
2026-06-02 - 9:57:42 AM PDT
-  Email viewed by Myka Hammock (MHammock@oaklandca.gov)
2026-06-02 - 12:45:38 PM PDT - IP address: 209.232.103.89
-  Document e-signed by Myka Hammock (MHammock@oaklandca.gov)
Signature Date: 2026-06-02 - 12:46:08 PM PDT - Time Source: server- IP address: 209.232.103.89 - Signature Appearance Selected: DRAW
-  Agreement completed.
2026-06-02 - 12:46:08 PM PDT



City of
Oakland

Powered by
Adobe
Acrobat Sign



CITY OF OAKLAND
Oakland Parks, Recreation & Youth Development

TO: Marc Barach, Chair, Parks and Recreation Advisory Commission
FROM: Tanya Nicholson, Public Service Representative
DATE: June 2, 2026
SUBJECT: **REQUEST FOR PARKS AND RECREATION ADVISORY COMMISSION TO SUPPORT (PRAC) TO APPROVE ROYAL GRAND DUCAL COUNCIL OF ALAMEDA & CONTRA COSTA COUNTIES INC. REQUEST FOR TICKET SALES AT DOOR, ALCOHOL BEVERAGE SALES, VENDOR SALES OF MERCHANDISE, TIPS AND DONATIONS AT THE CORONA ON XXXIV – CLASH OF THE TITANS TO BE HELD AT LAKESIDE PARK GARDEN CENTER (VISTA & GARDEN ROOMS), SATURDAY, JULY 18, 2026 FROM 5:00PM-9:30PM.**

SUMMARY

Oakland Parks, Recreation and Youth Development received a request from Royal Grand Council of Alameda and Contra Costa Counties Inc., a non-profit organization, which helps the Monarchs Charity Fund to be disbursed annually for those Charities in need and not subsidized by other available grants. Royal Grand Ducal Council of Alameda and Contra Costa are requesting approval to collect on-site ticket sales at the door, collection of onsite donations, allow entertainers to be given tips by audience member, ranging from \$1-\$10 donations, and vendor sales to be held at Lakeside Park Garden Center (Vista and Garden Rooms) on July 18, 2026. The applicant is aware of the additional permits required. Approval from the Parks and Recreation Advisory Commission is required per O.M.C. section 12.64.080.

BACKGROUND / LEGISLATIVE HISTORY

Royal Grand Ducal Council of Alameda and Contra Costa Counties Inc. were founded in 1998, a 501(c)3 non-profit organization operating in Alameda and Contra Costa Counties. The Royal Grand Ducal Council of Alameda and Contra Costa Counties purpose is to raise monies via the Monarchs Charity Fund.

PROJECT / PROGRAM DESCRIPTION

The event can raise monies upwards of a thousand dollars, providing much needed funds for beneficiaries like The Oakland LGBTQ Center and The Rainbow Community Center of Contra Costa County.

The following funds that are being requested to collect on site:

- Ticket sales at door \$75 per person
- For entertainers to receive tips from audience \$1.00 - \$10.00
- Alcohol Sales
- Donations

FISCAL IMPACT

There is no fiscal impact on Oakland Parks, Recreation and Youth Development. Royal Grand Ducal Council of Alameda & Contra Costa Counties Inc. is paying the associated rental fees for the event.

PUBLIC OUTREACH / INTEREST

Royal Grand Ducal Council of Alameda and Contra Costa Counties Inc. events are promoted through social media and community flyers.

RECOMMENDATION

Staff recommend that the Park and Recreation Advisory Commission to approve Royal Grand Ducal Council of Alameda & Contra Costa Counties Inc. request to collect on-site ticket sales at the door, collection of onsite donations, allow entertainers to be given tips by audience member, and vendor sales to be held at Lakeside Park Garden Center (Vista & Garden Rooms) on Saturday, July 18, 2026, from 5:00pm-9:30pm.

Respectfully submitted,

Tanya Nicholson

[Tanya Nicholson \(Jun 4, 2026 16:47:58 PDT\)](#)

Prepared by:

Tanya Nicholson

Public Service Representative

Zermaine Thomas

Reviewed by:

Zermaine Thomas

Special Events Coordinator

Sarah Herbelin

[Sarah Herbelin \(Jun 4, 2026 16:49:51 PDT\)](#)

Approved by:

Sarah Herbelin

Assistant Director, OPRYD

Identification of Support Documents:

Attachments: Exhibit A – Royal Grand Ducal Council of Alameda & Contra Costa Counties Inc. Proposal Letter (2026)

Exhibit B – Royal Grand Ducal Council of Alameda & Contra Costa Counties Proposal Letter (2024)



Royal Grand Ducal Council of Alameda & Contra Costa Counties Inc.

Tax ID: 94-3293892

Dear Parks and Recreation Advisory Commission:

On behalf of The Royal Grand Ducal Council of Alameda & Contra Costa Counties Inc. please accept this Proposal Letter as part of our application on for the use of Lakeside Park Garden Center on **July 18th 2026**, doors at 5pm ending at 9:30pm for our annual gala fundraiser called **Corona on XXXIV - Clash of The Titans**.

The Royal Grand Ducal Council of Alameda & Contra Costa Counties Inc. was founded in 1998 and we are a 501c3 non-profit organization operating in Alameda & Contra Costa Counties. Our purpose is to raise monies via the Monarchs Charity Fund to be disbursed annually for those Charites in need who are not heavily subsidized by other available grants. Partnering with local businesses, event spaces and fellow community leaders, we produce variety/vaudeville shows and all the performers in the show donate their time, talent and tips to The Monarchs Charity Fund to be dispersed at the end of the reign. These shows can raise monies upwards of a thousand dollars, providing much needed funds for beneficiaries like The Oakland LGBTQ Center on Lake Merritt & The Rainbow Community Center of Contra Costa County just to name a couple.

We would like to request permission to collect funds for a few different things on-site at the event that are very typical at our Organizatons Gala's. Below are the items we are requesting permission for.

We would like to collect payment for any last minute door ticket sales, \$75 per person.
We would also like to sell alcohol at the event as a part of our fundraising gala.

During the event we will have a few entertainers that we typically allow to be given tips by audience members, ranging from \$1 to \$10 donations per audience member.

We would also like to have two vendors on site selling Costume Jewelry and personal accessories ranging in prices, but typically ranging from \$10-\$500. These vendors would be responsible for processing their own payments and no funds for goods would be collected by our organization.

Thank you and the OPR YD staff for their support in ensuring our event is successful.

Sincerely,
Spencer Spencer
Board Chair
The Royal Grand Ducal Council of Alameda & Contra Costa Counties
Inc.



POST EVENT REPORT

Please complete and return the Post Event Report within 30 days after event date to Oakland Parks and Recreation Central Reservations Unit at 250 Frank H. Ogawa Plaza, 3rd Floor, Suite 3330, Oakland, CA 94612. If the event was held at a Recreation Center site, return the Post Event Report to the Site Supervisor at the Recreation Center.

I. GENERAL INFORMATION

Name of Event: Coronation 32 – Beyond Words: A

Location of Event: The Garden room – Lake Merritt

Date/Hours of Event: Sat July 13, 2024 5PM-10PM Permit No. _____

Event Contact Name: Aaron Lindsey Phone No. 415-203-7633

Event Contact Address: 1411 Center St #4 Oakland,

Is this a "first time" event at this location? Yes No If no, when was the event held previously?

1. Were Facility Rental/Set-up fees waived Yes No Not Applicable

2. Check other permits required for event?

- OPD Special Events Permit Food Handler's Permit Seller's Permit
- Charitable Solicitations Permit Certificate of Insurance Other – Please list

II. ATTENDANCE/COLLECTION OF FUNDS

1. Total number in attendance: 100

2. Were registration fees, donations or other fees collected on-site? Yes No Not Applicable

3. If yes, how many people registered? _____ How many people made donations? _____

4. What was the cost for registration? _____

5. How much was collected on site from registration fees? _____

6. How much was collected on site from donations? _____

7. How much was collected on site from other fees? _____

III. VENDOR INFORMATION

List all Vendors who participated at the event. (Attach additional sheets, if necessary):

Were all vendors in compliance per agreement? Yes No

If no, why not? _____

| Name of Vendor(s) (Attach additional sheets if necessary) | Non-Profit or For Profit Orgz'n? | Food (Describe) | Craft (Describe) | Seller's Permit Y/N |
|---|----------------------------------|-----------------|------------------|---------------------|
| Divi's Jewelrv | | | Yes | Yes |
| | | | | |
| | | | | |
| | | | | |

IV. COMMENTS

List ways in which the Applicant desires to improve the event, in the future (Attach additional sheets, if necessary): (For example: changes or additional vendors, location, change of hours, etc.)

List any problems, concerns, or other comments about your satisfaction in the way the event turned out? (Attach additional sheets, if necessary):

Submitted by: Aaron Lindsey Date: July 16, 2024

Approved by: Tanya Nicholson Date: Jun 4, 2026
Tanya Nicholson (Jun 4, 2026 16:47:58 PDT)
(OPR Staff)

Comments: _____